



# Model 6712

portion control bench scale

---



# portion control bench scale

NCI Model 6712 is designed for use in cafeterias, convenience stores, delicatessens, restaurants, candy shops or anywhere space is a premium.

## Features & Benefits

- ◆ **Low Profile** Only 2.5" high.
- ◆ **Small Footprint** 10" x 10" platter.
- ◆ **Easy to Read** Six-digit LCD external display with large 0.5" characters, tactile keys, 7 ft. cable and Velcro™ for mounting.
- ◆ **Accurate and Reliable** Precision load cell and quality electronics ensure repeatable weight measurements and trouble-free operation.
- ◆ **Simple to Use** Reduces operator training time.
- ◆ **Interfaces** RS-232 only. NCI standard protocol only.
- ◆ **Auto Zero Tracking** Zero light indicator and manual control when out of range.
- ◆ **Quick Disconnects** Make all cable connections easily.
- ◆ **Construction** Stainless steel weighing area with full skirt around perimeter of base, except where connectors are located at rear of scale.

## Options

- ◆ **Display Post** 12" high post for attachment to remote display.
- ◆ **International Power Supply** 230 VAC, 50 Hz power supply. Cable terminated with a universal connector.
- ◆ **Cables** Interface cables available for PCs and specific ECRs.
- ◆ **Display Brackets** Attach remote display to scale base.

## Specifications

### ◆ Capacity and Resolution

Ounces  
160 x 0.1

### ◆ Dimensions

Weigh Platter: 10" x 10" (254 mm x 254 mm)  
Remote Display Enclosure: 5.8" W x 3.0" H x  
1.4" D max (147 mm x 76 mm x 35 mm)  
Adjustable Height: 2.5" – 3.0" (63 mm – 76 mm)

### ◆ Power

Input: Wall mount transformer 120 VAC  
(+10% -15%)/ 60 Hz (±3 Hz)  
Standard 3 wire with ground input  
Output: 15 VDC @ 0.3 Amps minimum

### ◆ Operating Environment

41°F to 104°F (5°C to 40°C) (Class III device) 10% to 90% RH (non-condensing)

### ◆ Agency Approvals

Legal for Trade, NTEP Class III,  
USA COC #00-096  
Power Supply: UL Listed, CSA Certified

## Dimensions

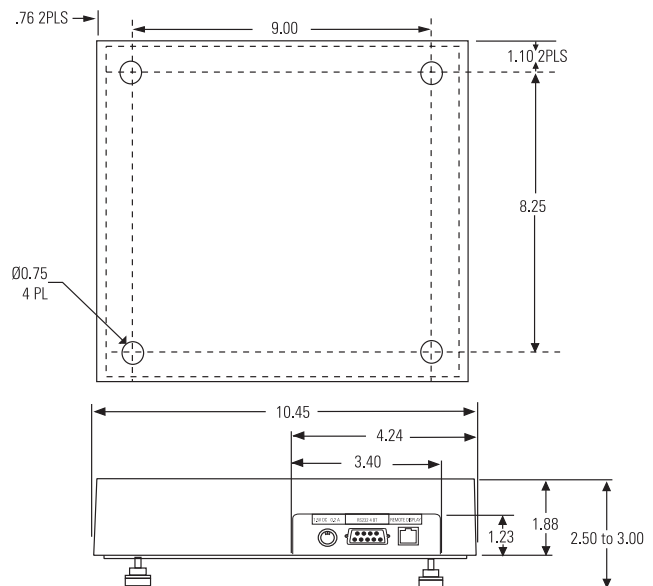

© Avery Weigh-Tronix 2004. All rights reserved. This publication is issued to provide outline information only which, unless agreed by Avery Weigh-Tronix in writing, may not be regarded as a representation relating to the products or services concerned. Avery Weigh-Tronix reserves the right to alter without notice the specification, design, price or conditions of supply of any product or service.

**Avery Weigh-Tronix**  
(Retail North America)  
1000 Armstrong Drive, Fairmont, MN 56031

PH Toll-Free: 800-637-0529  
PH: 507-238-8702  
FAX: 507-238-8271

E-mail: sales@salterbrecknell.com  
Internet: www.salterbrecknell.com

# Avery Weigh-Tronix



Product complies with F.C.C.